

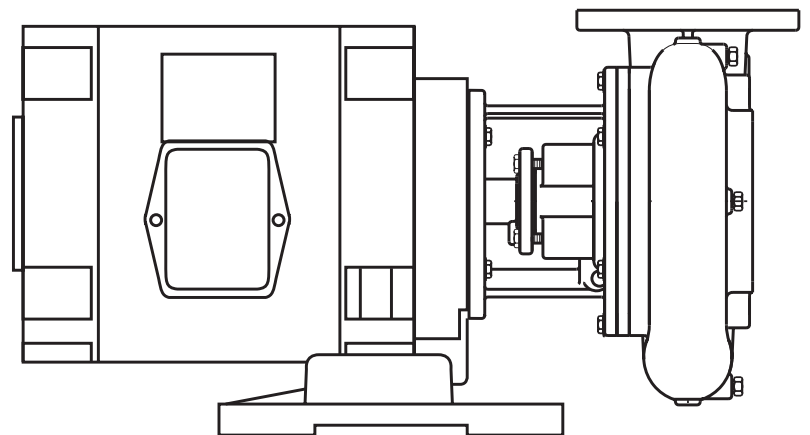

FAIRBANKS NIJHUIS™

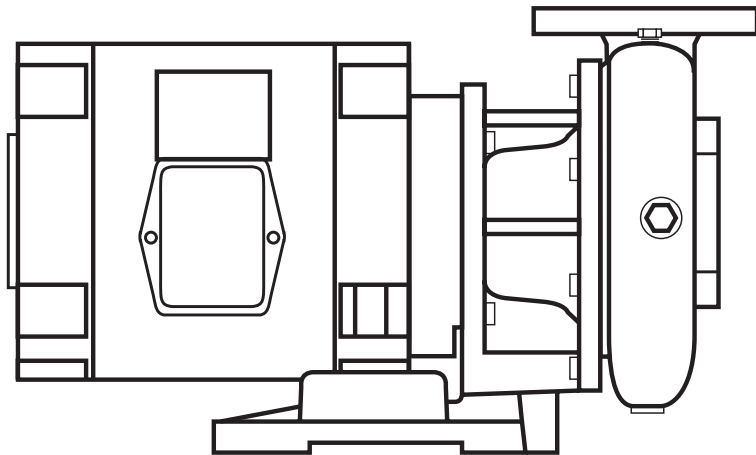

1500 AND 2500 SERIES SINGLE STAGE END SUCTION PUMPS

INSTALLATION, OPERATION AND MAINTENANCE MANUAL

NOTE! To the installer: Please make sure you provide this manual to the owner of the equipment or to the responsible party who maintains the system.

1500 and 2500 Series Single Stage End Suction Pumps Table of Contents

Description	Page
Models 1500 and 2500 Installation Instructions	3–6
Models 1500 and 2500 Operation Instructions	7–10
Models 1550, 1530, 1520, 2550, 2530 and 2520 Maintenance and Repair Instructions	11–19
Models 1550, 1530 and 1520 List of Parts	20
Model 1550 Exploded View	21
Model 1530 Exploded View	22
Model 1520 Exploded View	23
Models 2550, 2530 and 2520 List of Parts	24
Model 2550 Exploded View	25
Model 2530 Exploded View	26
Model 2520 Exploded View	27

CALIFORNIA PROPOSITION 65 WARNING:

▲ WARNING This product and related accessories contain chemicals known to the State of California to cause cancer, birth defects or other reproductive harm.

MODELS 1500 AND 2500 INSTALLATION INSTRUCTIONS

PUMP LOCATION:

You probably have spent considerable time planning where your pump will be located; however, you may have overlooked some factor that may affect pump operation or efficiency.

The pump should be located as close to the liquid source as possible so that the suction line can be short and direct. It should be located in a clean, open area, where it is easily accessible for inspection, disassembly and repair. Pumps installed in dark, dirty areas or in cramped locations are often neglected, which can result in premature failure of both the pump and the driver.

The Fairbanks Nijhuis pump must be installed horizontally. Install isolating valves on each side of the pump so maintenance can be performed without draining the system. Special mounting requirements may be necessary if the pump is to be mounted near a noise or vibration sensitive area.

The installation **must** be evaluated to ensure that the net positive suction head available (NPSHA) meets or exceeds the net positive suction head required (NPSHR), as stated by the pump performance curve.

FOUNDATION:

The foundation for your pump must be sufficiently rigid to absorb any vibration and stress encountered during pump operation. A raised foundation of concrete is preferable for most floor mounted pumps. The raised foundation assures a satisfactory base, protects against flooding, simplifies moisture drainage, and facilitates in keeping the area clean.

Your pump should be firmly bolted to the foundation, whether it is a raised concrete base, steelwork wall, or structural member. The mounting bolts or lag screws should be accurately located per the applicable Fairbanks Nijhuis dimension sheet. (See Fig. 1.)

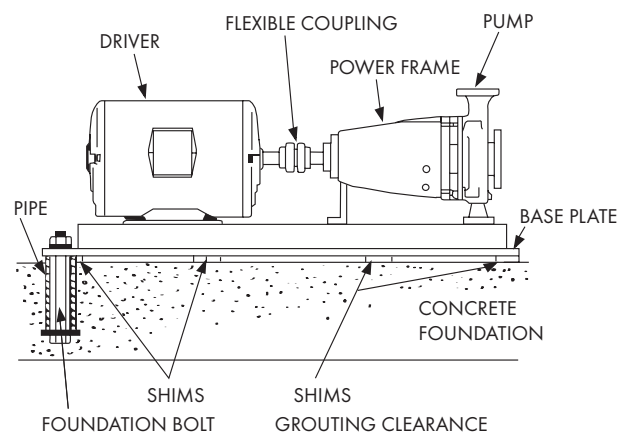

Fig. 1 Foundation for Frame Mounted Pumps.

LEVELING THE PUMP:

Leveling the pump will require enough shims to support the base plate near the foundation bolts and at any points of the base plate carrying a substantial weight load. The shims should be large enough to allow a gap of 3/4" to 1-1/2" between the base plate and foundation for grouting.

IMPORTANT:

The pump base must be set level to avoid any mechanical difficulties with the pump or motor. The 1500/2500 pump was properly aligned, if supplied with a motor, at the factory; however, since the pump base is flexible, it may spring and twist during shipment. Do not pipe the pump until it is realigned. Realign the base after piping is completed and after the pump is grouted in and bolted down.

NOTE: It may be necessary to readjust the alignment from time to time while the unit and foundation are new. Realignment will prevent premature bearing failure, excessive vibration or shaft failure.

Ensure that proper hydronic accessories (such as pressure relief valves, thermal expansion tanks and flow/pressure control devices) are installed in the system. Consult the responsible party for your system to ensure these devices are installed and of the proper size.

GROUTING THE INSTALLATION:

Grouting the base plate prevents lateral movement of the base plate and improves the vibration absorbing characteristics of the foundation by increasing its mass. A wooden dam should be constructed around the base plate to contain the grout while it is being poured. The dam can either be built tight against the base plate, or slightly removed from it as desired. (See Fig. 2.) The entire base plate should be completely filled with non-shrinkable type grout. The grout should be puddled frequently to remove any air bubbles.

ROTATION:

Pump rotation is clockwise when viewed from the back of the motor. An arrow is also located on the pump to show the direction of rotation.

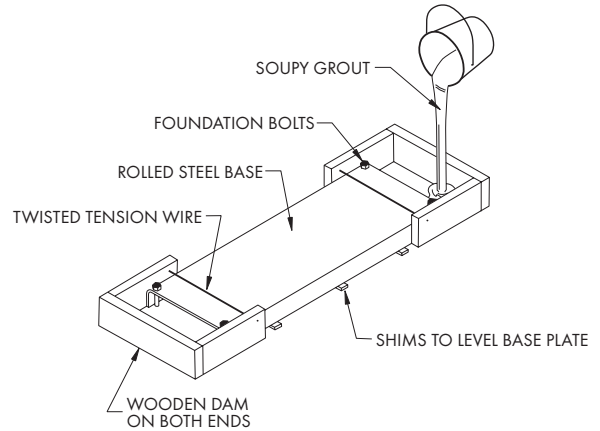

Fig. 2 Grouting the Base for Frame Mounted Pumps.

WARNING: Sudden Start-up Hazard

Disconnect and lock out power source before servicing. Failure to follow these instructions could result in serious personal injury, death or property damage.

INITIAL ALIGNMENT OF THE FLEXIBLE COUPLING:

The pump and driver were accurately aligned at the factory; however, it is impossible to maintain this alignment during shipping and handling. Therefore, it will be necessary to realign the pump and driver. Flexible couplings are not universal joints and they should not be used to compensate for misalignment of the pump and motor shafts. Their function is to transmit power from the driver to the pump while compensating for thermal expansion and shaft end movement. The coupling faces should be far enough apart so that they do not make contact when the motor shaft is forced to the limit of the bearing clearance toward the pump shaft.

To properly align the coupling, you will need a taper gauge or set of feeler gauges, and a straight edge.

There are two types of misalignment encountered with flexible couplings: angular misalignment, in which the shafts are not parallel, and parallel misalignment, where the shafts are parallel but not on the same axis.

To check angular alignment, insert a feeler gauge or taper gauge at any four places 90° apart around the coupling halves. Insert shims under the driver feet until the same reading is obtained at all four check points. The pump and driver will then be in angular alignment.

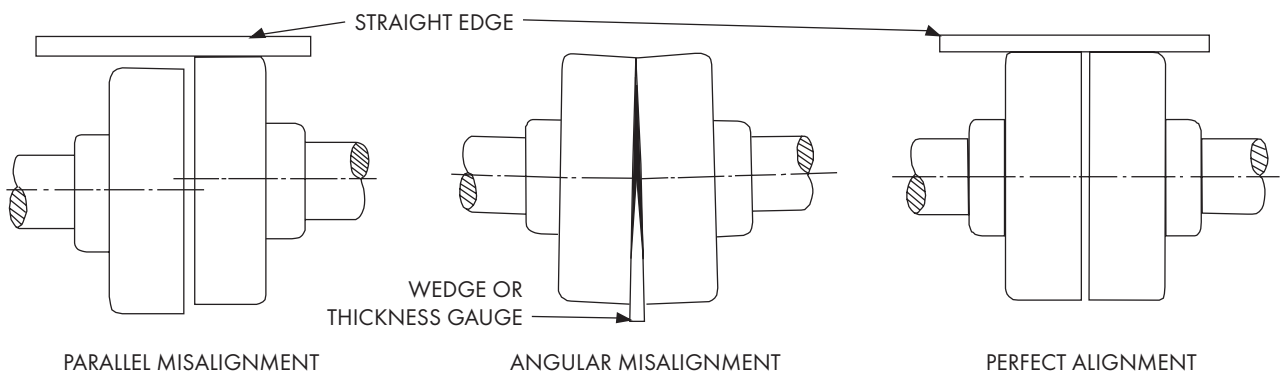

Fig. 3 Flexible Coupling Alignment.

To check parallel alignment, hold a straight edge against the edges of the coupling halves at any four places 90° apart around the coupling. The straight edge should be parallel to the pump and driver shafts at all times. Insert shims until the straight edge lies flat against both coupling halves at all four checkpoints. The pump and driver will then be in proper parallel alignment. (See Fig. 3.)

For fine alignment, 3500 RPM operation, for all other coupler types.

A dial indicator should be used when greater alignment accuracy is required. Use the following alignment tolerances unless specified otherwise by the coupling manufacturer. On sleeve type couplings, make sure there is at least 1/8" end clearance between the sleeve and the two coupling halves.

To check angular misalignments, mount the dial indicator base to the coupling half and position the dial indicator button on the front or rear face of the opposite coupling half. Set the dial to zero, then rotate both coupling halves together, making sure the indicator button always indicates off the same spot. Misalignment values within 0.004 inches TIR per inch of coupler radius is permissible.

To check parallel misalignment, mount the dial indicator base to one coupling half, or shaft and position the dial indicator button on the outside diameter of the opposite coupling half. Set the dial to zero. Rotate both coupling halves together, making sure the indicator button always indicates off the same spot. Misalignment within 0.004 inches TIR is permissible.

PIPING:

SUCTION PIPING:

The suction piping should be short – but no less than ten pipe diameters in length – and direct with as few elbows and fittings as possible to keep head loss from friction at a minimum. The suction pipe should, however, provide a minimum uninterrupted length, equal to ten pipe diameters, to the pump suction flange. A horizontal suction line should have a gradual rise to the pump and pass under any interfering piping.

The suction pipe diameter should be at least the same diameter as the suction nozzle on the pump (and preferably larger). Use of a smaller diameter pipe will result in loss of head due to friction. All joints must be tight to maintain prime on the pump.

REDUCERS:

Eccentric reducers should be installed directly at the suction nozzle, with the taper at the bottom to prevent air pockets from forming. Straight taper reducers should never be used in a horizontal suction line because of the air pocket that is formed at the leg of the reducer and the pipe. (See Fig. 4.)

DISCHARGE PIPING:

Discharge piping should also be as short and direct as possible, with few elbows and fittings, to reduce head loss from friction.

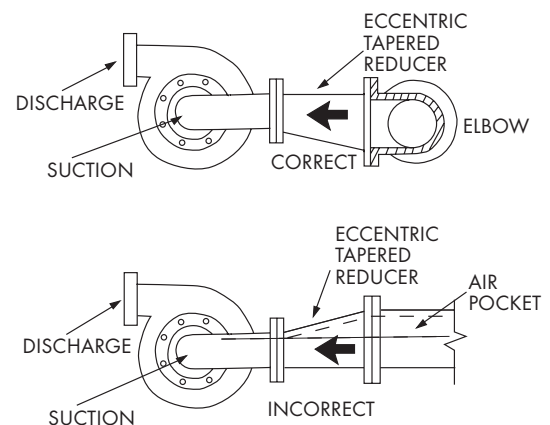

Fig. 4 Installation of Tapered Reducers.

PIPE:

The discharge pipe diameter should be the same as, or larger than, the discharge nozzle diameter.

DISCHARGE VALVES:

The discharge piping should include a check valve and a gate valve. The check valve should be located between the gate valve and the pump. If an increaser is used in the discharge piping, the increaser should be installed between the pump nozzle and the check valve. The check valve protects against a reverse flow of the liquid if the driver fails. (See Fig. 5.)

The gate valve is used in the priming operation as a throttling valve to control pump volume. It is also used to shut down the pump for inspection and maintenance.

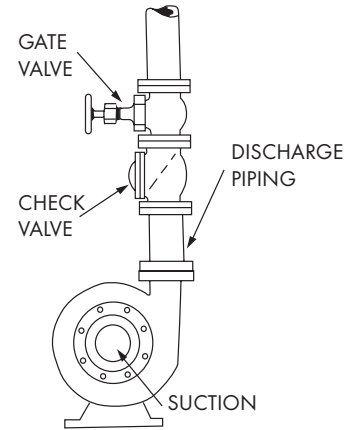

Fig. 5 Gate Valve and Check Valve.

MODELS 1500 AND 2500 OPERATION INSTRUCTIONS

Centrifugal pumps operate under a wide range of conditions. The pump you have selected exactly fits your specific requirements. Before putting your pump into operation, however, there are certain basic ground rules that must be followed to assure maximum efficiency, long pump life, and maintenance-free service.

Centrifugal pumps should never be started or run dry. Operating a pump dry can cause burning of the packings or seal, resulting in destruction of the packings or seals, and possible scoring of the pump shaft. To prevent the pump from being run dry, the pump should be primed before starting it.

A centrifugal pump should not be throttled, or the volume controlled on the suction side of the pump. Throttling the pump on the suction side not only reduces the capacity, but also reduces pump efficiency and, more importantly, can cause serious damage to the pump due to cavitation. Cavitation occurs when the pressure at any point inside the pump drops below the vapor pressure of the liquid. The liquid flashes and forms vapor bubbles. These bubbles move along with the liquid into a higher pressure area, where the bubbles collapse or implode, creating an area of low pressure. The implosion phenomenon is characterized by a crackling noise and sometimes by loud knocking as the vapor bubbles are collapsed. Repetition of this action causes a wearing away of the metal on the impeller and other parts of the pump, and if allowed to continue can result in serious damage to the pump.

Pump capacity can be effectively controlled by use of a throttling valve in the discharge piping. Most centrifugal pumps can be operated for brief periods of time with the throttling valve closed without building up excessive pressure or overloading the drive unit. In fact, a centrifugal pump operating against a closed discharge line at its rated capacity actually requires less power to operate than it does when the throttling valve is open.

The pump should never be started with the throttling valve completely closed, however, because a condition of water hammer could exist. The condition of water hammer is caused by an increase in pressure due to changes in velocity of the liquid flowing through the pipe line. When the velocity is changed by closing a valve or by some other means, the magnitude of the pressure produced is frequently much greater than the static pressure on the line, and may cause rupture or damage to the pump, piping, or fittings. Water hammer may be controlled by regulating valve closure or by the use of relief valves and slow-closing check valves.

On pumps equipped with packings, there should be sufficient leakage from the packing to ensure lubrication of the packing and effective cooling of the stuffing box. The packing glands should always be adjusted evenly and not too tightly. Overtightening the packing can generate heat which will burn the packing and cause scoring of the shaft, making it necessary to replace both the shaft and the packings.

Adequate precautions should be taken to prevent freezing of liquid in the pump when the pump is not in operation. If there is any possibility of freezing, the water should be drained off by removal of the plugs provided in the pump casing.

All mounting bolts and piping connections must be firmly tightened to prevent excessive vibration, leakage, and possible damage to the pump. The mounting bolts are particularly important. If they are not firmly tightened, the base plate upon which the pump is mounted may deflect, causing a misalignment of the pump and the driver.

STARTING THE PUMP:

In order to start your pump, it will first be necessary to prime it.

PRIMING THE PUMP:

Your pump will not operate satisfactorily until it is primed. All air must be expelled from the suction piping and pump casing and replaced by the liquid to be pumped. There are several methods of priming pumps. The one you select will depend on your specific requirements.

FLOODED SUCTION PRIMING:

This method of priming a pump is relatively simple. The liquid source is located above the pump; all that is necessary to prime the pump is to open the air vent valve or plug in the pump casing and to crack the gate valve in the suction line. The suction line and pump should be filled slowly until a steady stream of liquid is observed flowing from the air vent. After your pump is operating, it is recommended that the air vent valve or plug be opened again to ensure that all air has been expelled from the pump casing.

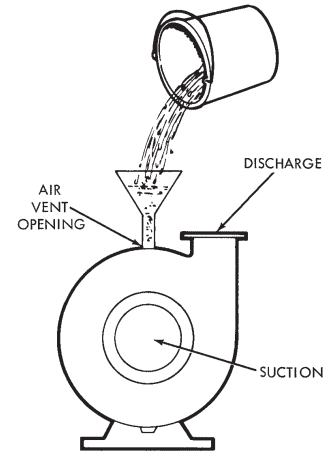

Fig. 6 Priming by Hand.

FOOT VALVE PRIMING:

A foot valve can be used for priming on suction lift applications. The foot valve (located at the bottom end or foot of the suction piping) functions as a check valve which allows flow in one direction only, toward the pump.

Initial priming is accomplished by completely filling the suction piping and pump casing with the liquid to be pumped. This can be done by removing the air vent valve or plug at the top of the pipe casing and inserting a pipe nipple in the orifice with an appropriate increaser to accommodate a hose connection. A priming line can also be inserted in the discharge piping between the check valve and the pump, or the priming can be done with a bucket and funnel. The important thing is to completely fill the suction pipe and pump casing with liquid.

When the pump is started, the vacuum created by pumping the priming fluid combined with atmospheric pressure in the liquid well forces liquid into the suction piping, thus opening the valve and keeping it open until the pump is shut down. When the pump is shut down, the liquid being pumped reverses its flow, causing the valve to close. The liquid is now trapped in the suction piping and pump casing, thus maintaining a prime on the pump.

VACUUM PRIMING:

Vacuum priming consists of removing air from the pump casing and suction piping and drawing liquid into them by means of a vacuum-creating device. The types of vacuum equipment range from a simple head pump to complex central priming systems. Your specific priming requirements will govern what type of vacuum primer you use.

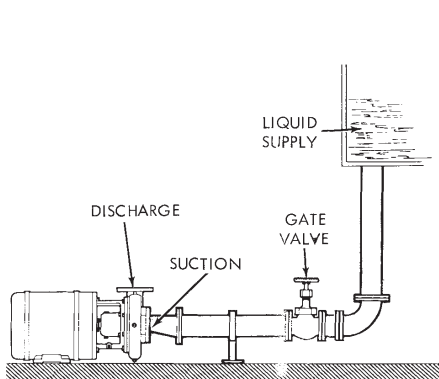

Fig. 7 Flooded Suction Priming.

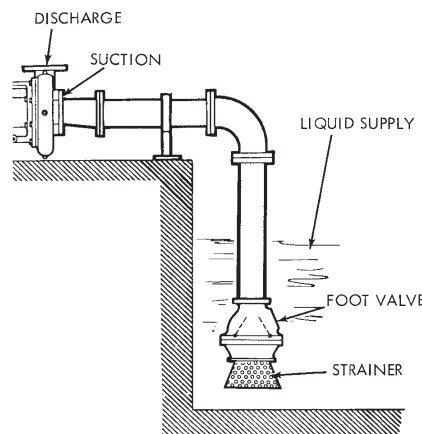

Fig. 8 Priming with a Foot Valve.

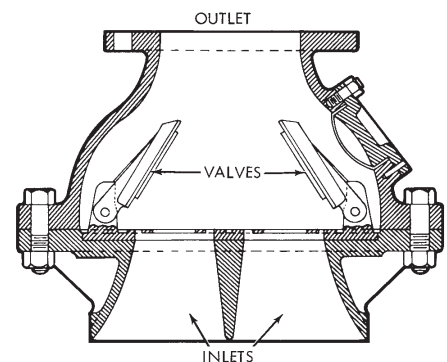

Fig. 9 Foot Valve Cutaway.

AIR EJECTOR:

One type of vacuum primer is the air ejector. If liquid under pressure, or steam, is available, an ejector can be used. The ejector is connected to the air vent orifice. A stream of the ejecting medium is passed through the ejector, creating a vacuum in the ejector and drawing air from the pump casing and suction piping. When liquid flows steadily from the ejector discharge pipe, the pump is primed.

VACUUM PUMPS:

Rotary or reciprocating pumps are frequently used as vacuum pumps. They fall into two categories: wet-vacuum and dry-vacuum. The principle of operation is essentially the same; however, the dry-vacuum pump cannot accommodate a liquid and air mixture, while the wet-vacuum pump can accommodate liquid, air, or a combination of both.

Vacuum pumps can be installed as part of a central priming system servicing many pumps, as an automatic priming system, or as a manually controlled independently driven pump.

The suction piping of the vacuum pump is connected to the air vent orifice on the pump to be primed. The vacuum produced by the vacuum pump removes air from the turbine pump suction piping and casing, and draws liquid from the liquid well into the turbine pump. Dry-vacuum pumps must be installed so that no liquid is taken into the air pump. Installation of a water trap or use of a vacuum tank is recommended for dry-vacuum pumps.

INDUCTOR PRIMING:

On suction lift applications, it may be desirable to prime your pump with a priming inductor. This type of primer comprises a liquid nozzle and an inductor at the foot end of the suction piping. The nozzle and inductor are connected to a high pressure liquid supply such as a city water service.

The pump is primed by opening the valve in the pressure line. This will allow the liquid to flow through the nozzle and into the inductor. The velocity of the high pressure liquid drives the liquid into the suction piping and up to the pump, thus completing the priming operation.

POSITION OF DISCHARGE GATE VALVE WHEN STARTING:

The discharge gate valve should partially be closed when a high or medium head centrifugal pump is started, because this type of pump requires much less power with the gate valve closed than when it is operated at rated capacity and head with the discharge gate valve open. As soon as the pump is up to operating speed, the discharge gate valve should be opened to the desired position.

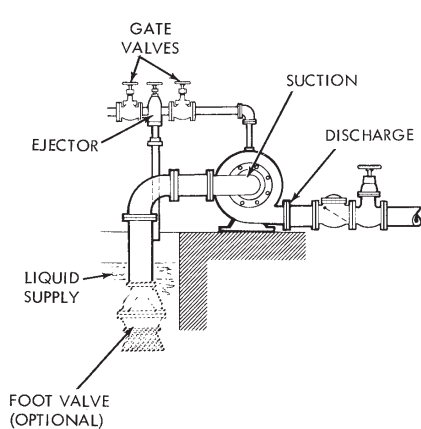

Fig. 10 Priming by Ejector.

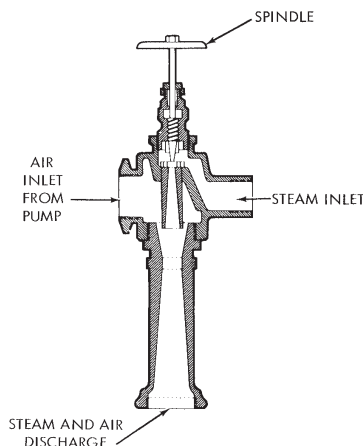

Fig. 11 Ejector Cutaway.

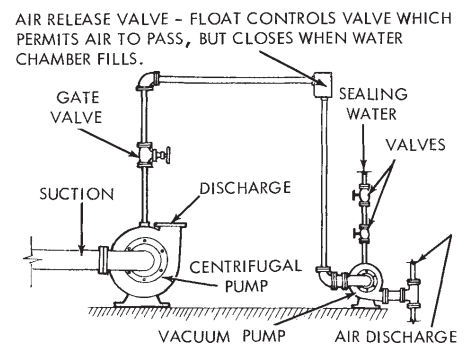

Fig. 12 Vacuum Pump Priming.

POSITION OF SUCTION PIPING GATE VALVE:

In flooded suction applications, the gate valve is opened when the pump is being primed and will remain open for starting and operation.

COOLANT VALVES:

Valves in the cooling liquid line should be opened prior to starting the pump, and should remain open while the pump is in operation unless it is desirable to check the rate of leakage from the stuffing box.

SHUTTING DOWN THE PUMP:

To shut down your pump, simply close the discharge gate valve and shut down the motor. If it is necessary for the pump to maintain its prime while it is shut down, it is advisable to install either a foot valve or a check valve in the suction piping.

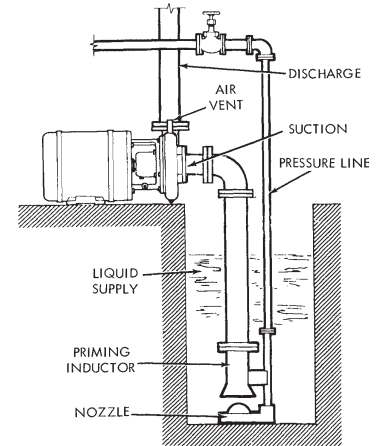

Fig. 13 Inductor Priming.

**MODELS 1550, 1530, 1520, 2550, 2530 AND 2520
MAINTENANCE AND REPAIR INSTRUCTIONS**

NOTE:

This repair manual is applicable to pump Models 1550, 1530, 1520, 2550, 2530 and 2520.
All photos illustrate Model 1520 and 2520.

ATTENTION: SAFETY WARNINGS:

Read and understand all warnings before installing or servicing pump.

OPERATIONAL LIMITS: *

Maximum Operating Pressure: 175 psi at temperatures to 150°F (65.6°C)

Maximum Operating Temperature: 225°F (107°C)

* See ASTM A126/ANSI B16.1 for pressure/temperature ratings of flanges.

ELECTRICAL SAFETY:

WARNING: Electrical Shock Hazard

All electrical connections are to be made by a qualified electrician in accordance with all codes and ordinances. Failure to follow these instructions could result in serious personal injury, death or property damage.

WARNING: Electrical Overload Hazard

Ensure all motors have properly sized overload protection. Failure to follow these instructions could result in serious personal injury, death or property damage.

WARNING: Sudden Start-Up Hazard

Disconnect and lock out power source before servicing. Failure to follow these instructions could result in serious personal injury, death or property damage.

HIGH TEMPERATURE SAFETY:

WARNING: Hot Surface Hazard

If pumping hot water, ensure guards or proper insulation is installed to protect against skin contact to hot piping or pump components. Failure to follow these instructions could result in serious personal injury, death or property damage.

WARNING: Spraying Water Hazard

When servicing pump replace all gaskets and seals. Do not reuse old gaskets or seals. Failure to follow these instructions could result in serious personal injury, death or property damage.

HIGH PRESSURE SAFETY:

WARNING: High Pressure Hazard

The pump is rated at a maximum of 175 psi at 150°F. Do not exceed this pressure. Install properly sized pressure relief valves in system. Failure to follow these instructions could result in serious personal injury, death or property damage.

WARNING: Expansion Hazard

Water expands when heated. Install properly sized thermal expansion tanks and relief valves. Failure to follow these instructions could result in serious personal injury, death or property damage.

SERVICE:

Your Fairbanks Nijhuis pump requires no maintenance other than periodic inspection, occasional cleaning and lubrication of bearings (Model 1520/2520 only). The intent of inspection is to prevent breakdown, thus obtaining optimum service life. The liquid end of the pump is lubricated by the fluid being pumped and therefore does not require periodic lubrication. The motor, however, may require lubrication, in which case the motor manufacturer's recommendation should be followed.

LUBRICATION OF IMPELLER SHAFT BEARINGS:

The Model 1520/2520 pump is available with three options for lubricating the shaft bearings. They are:

1. Regreasable (standard)
2. Oil Lubrication
3. Sealed Bearings, Permanent Lubrication

Regreasable bearings will require periodic lubrication and can be accomplished by using the zerk or lubrication fittings in the cartridge cap and power frame. Lubricate the bearings at regular intervals using a grease of high quality. Polyurea base grease is recommended as lubricants for pumps operating in both wet and dry locations. Mixing of different brands of grease should be avoided due to possible chemical reactions between the brands which could damage the bearings. Accordingly, avoid vegetable – or animal-based grease which can develop acids, as well as grease containing rosin, graphite, talc and other impurities. Under no circumstances should used grease be reused.

Overlubrication should be avoided as it may result in overheating and possible bearing failure. Under normal application, adequate lubrication is assured if the amount of grease is maintained at 1/3 to 1/2 the capacity of the bearing and space surrounding it.

In dry locations, each bearing will need lubrication at least every 600 hours of running time or every 6–12 months, whichever is more frequent. In wet locations, the bearings should be lubricated at least after every 300 hours of

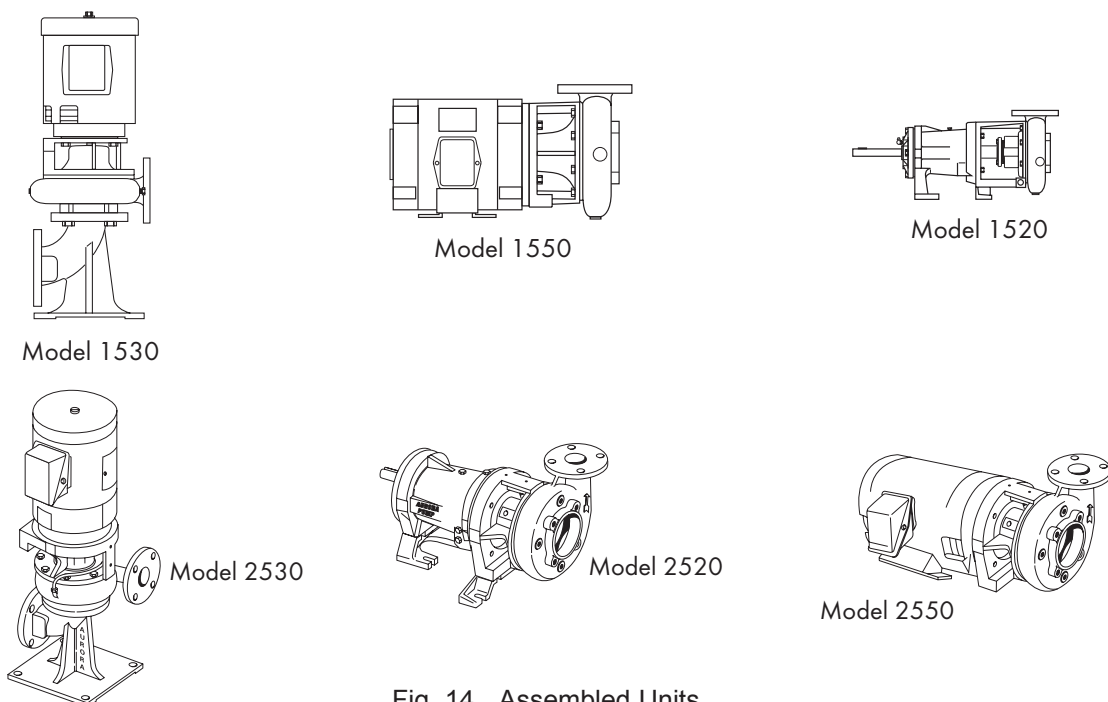

Fig. 14 Assembled Units

running time or every 4–6 months, whichever is more frequent. A unit is considered to be installed in a wet location if the pump and motor are exposed to dripping water, to the weather, or to heavy condensation such as is found in unheated and poorly ventilated underground locations.

Oil lubricated bearings are optional on Model 1520/2520 pumps. A fixed oil level is maintained with the power frame by an oiler which allows visual indications of reserve oil. At initial installation and before starting a unit that has been shut down for repairs or for any extended length of time, run enough 10W-30 weight motor oil through the oiler to maintain a constant oil level to ensure that the bearing will never be without an oil supply. Oil will have to be added at intervals to maintain a constant level in the oiler. This interval can be determined only by experience.

Under working conditions, oil will break down and need to be replaced at regular intervals. The length of these intervals will depend on many factors. Under normal operation, in clean and dry locations, the oil should be changed about once a year; however, when the pump is exposed to dirt contamination, high temperatures (200°F or above) or a wet location, the oil may have to be changed every 2–3 months.

CAUTION:

Use normal fire caution procedures when using any petroleum cleaner.

The motor that drives your Fairbanks Nijhuis pump may or may not require lubrication. Consult the manufacturer's recommendations for proper maintenance instructions.

REPAIRS:

Before starting any work, ensure the electrical power is locked out, the system pressure has been lowered to 0 psi and temperature of the unit is at a safe level.

The pump may be disassembled using the illustrations and text provided. Although complete disassembly is covered, it will seldom be necessary to completely disassemble your Fairbanks Nijhuis pump.

The illustrations accompanying the disassembly instructions show the pump at various stages of disassembly. The illustrations are intended to aid in the correct identification of the parts mentioned in the text.

Inspect removed parts at disassembly to determine if they can be reused. Ball bearings that turn roughly or show wear should be replaced. Cracked castings should never be reused. Scored or worn pump shafts should be replaced. Gaskets should be replaced at reassembly simply as a matter of economy. They are much less expensive to replace routinely than to replace singly as the need arises.

WARNING: Sudden Start-Up Hazard

Disconnect and lock out power source before servicing. Failure to follow these instructions could result in serious personal injury, death or property damage.

WARNING: Hot Surface Hazard

If pumping hot water, ensure guards or proper insulation is installed to protect against skin contact to hot piping or pump components. Failure to follow these instructions could result in serious personal injury, death or property damage.

WARNING: High Pressure Hazard

The pump is rated at a maximum of 175 psi at 150°F. Do not exceed this pressure. Install properly sized pressure relief valves in system. Failure to follow these instructions could result in serious personal injury, death or property damage.

WARNING: Spraying Water Hazard

When servicing pump replace all gaskets and seals. Do not reuse old gaskets or seals. Failure to follow these instructions could result in serious personal injury, death or property damage.

DISASSEMBLY:

Disassemble only what is needed to make repairs or accomplish inspection. (See Figure 26/29 for Model 1550/2550, Figure 27/30 for Model 1530/2530 and Figure 28/31 for Model 1520/2520.)

1. Disconnect and lockout power source to prevent drive unit from being energized during disassembly.
2. Unscrew the two drain plugs (4) from the casing (6). On Model 1530/2530, remove plugs (74 and 75) to drain pump. Also unscrew the two plugs (4) from casing (6).
3. Remove all relief, cooling, flushing or drain lines from pump, including compression connections (1 and 2) and tubing (3). The sealing tube assembly (optional – 69, 70, 71 and 76) should be removed at this time. Break suction and discharge connections unless it is intended to remove the power frame or motor assembly and leave casing (6) in the line. On Model 1530/2530, break discharge connections only, unless it is desired to remove base (73). Remove capscrews (39) and lift pump assembly from base (73). Remove gasket (72).
4. On Model 1520/2520, remove the flexible coupling from between the pump and motor. Next unscrew the bolts that hold support(s) (41 and 64) to the base and slide the pump out to be worked on.
5. Remove capscrews (5) and pull casing (6) from bracket (35) and cover (26). Remove gasket (8).
6. Unscrew impeller screw (9) and remove washer (9A), taking care not to damage gasket (9B) or capscrew seal (9C).
7. Slide impeller (11) and impeller key (12) from the shaft, again taking care not to damage gasket (10) located behind impeller. Remove gasket (10).
8. Wear ring(s) (7 and 16) are pressed into their housings with an interface fit and must be removed with a puller. New ring(s) should be used for reassembly since it is likely that during removal this fit will be lost. Do not remove wear rings if not being replaced.
9. Impeller wear rings (optional – 14 and 15) are pressed on and must be cut off if replacement is necessary. If they are turned off in a lathe, take care not to cut into the impeller.
- 10a. For Models 1550, 1530, 1520: The various types of stuffing boxes may be disassembled as follows:

PACKING (STANDARD, WATER COOLED, AND WITH LANTERN RING):

- A. Remove adjusting nuts (21), gland clamps (22), gland halves (23) and studs (24), if used. For standard pumps remove capscrews (65).
- B. Unscrew capscrews (20) (not required on 7" bore pumps) or (5) and remove cover assembly (26). The throat of cover (26) should be checked for excessive wear.
- C. Shaft sleeve (25) is a slip fit on the shaft and should be easily removed unless the pump has been in service for a long time. In this case it may be necessary to use a puller. Take care to prevent damaging the surface of the sleeve. Replace the sleeve if it is grooved from wear. Pin (61) may be removed from sleeve (25) if necessary.
- D. All packing (28) and lantern ring (29), (if used) must now be removed from the packing box and the cavity thoroughly cleaned to allow new packing to fit properly.

MECHANICAL SEAL (OPTIONAL):**CAUTION:**

The mechanical seal (see Figure 25) is a precision product and must be treated as such. During removal, great care must be taken to avoid dropping any part of the seal. Take particular care not to scratch the lapped faces on the washer or the sealing seat. If any wear of the seal faces is noted, it is recommended to replace with a new seal during reassembly.

- A. Remove capscrews (65) and slide gland (23) (including the seal flexible cup and stationary seat) from either cover assembly (26) or water jacket (18). Take care in moving gland (23) not to damage gasket (66).
- B. Unscrew capscrews (20) (not required on 7" bore pumps), or (5) and remove cover assembly (26). The throat of cover (26) should be checked for excessive wear.

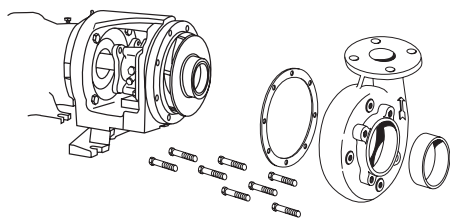

Fig. 15 1520 Casing, Gasket, and Wear Ring Removed.

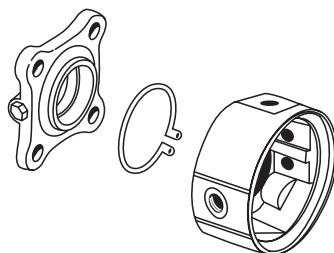

Fig. 16 1520 Water Jacket Removed.

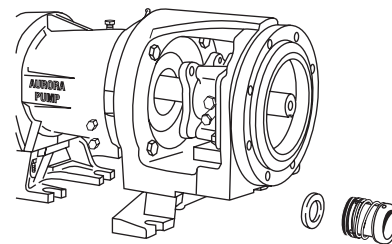

Fig. 17 1520 Mechanical Seal Removed.

C. Slide sleeve (25) with rotating parts of mechanical seal (27) from the shaft. The sleeve should be carefully cleaned to remove any residue that may remain in the seal area. The rubber in the seal may have partially adhered to the sleeve. The sleeve must also be checked for abrasion or corrosion that can occur when fluid residue penetrates between the seal (27) and sleeve (25). The sleeve under the seal may be polished lightly to a 32RMS finish before reassembly. Do not reuse a pitted sleeve. Pin (61) maybe removed from the sleeve (25) if necessary.

D. Remove gland (23) and gasket (66).

E. The seal flexible cup and stationary seat should be pressed out of the gland (23) and the cavity cleaned of all residue. Make sure that the 1/32" radius in the seal seat cavity is not damaged during disassembly since a sharp edge can easily cut the flexible cup during reassembly.

- 10b. For Models 2550, 2530, 2520: Slide sleeve (25) with rotating parts of mechanical seal (27) from the shaft. The sleeve should be carefully cleaned to remove any residue that may remain in the seal area. The rubber in seal (27) may have partially adhered to the sleeve. The sleeve must also be checked for abrasion or corrosion that can occur when fluid residue penetrates between the seal (27) and sleeve (25). The sleeve under the seal may be polished lightly to a 32 RMS finish before reassembly. Do not reuse a pitted sleeve. Pin (61) may be removed if necessary.

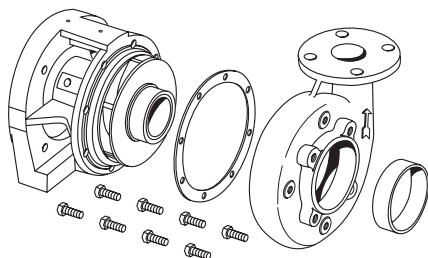

Fig. 18 2520 Casing, Gasket, and Wear Ring Removed.

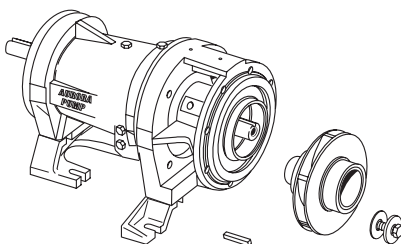

Fig. 19 2520 Water Jacket Removed.

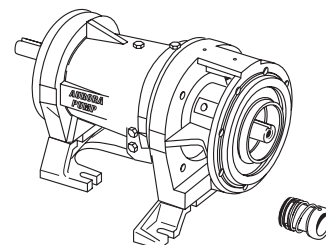

Fig. 20 2520 Mechanical Seal Removed.

CAUTION:

The mechanical seal (see Figure 25) is a precision product and must be treated as such. During removal, great care must be taken to avoid dropping any part of the seal. Take particular care not to scratch the lapped faces on the washer or the sealing seat. If any wear of the seal faces is noted, it is recommended to replace with a new seal during reassembly.

11. For Models 1550, 1530, 1520: The water jacket (optional – 18) may now be removed by snapping retaining ring (17) off cover (26). Note position of water jacket to assure proper alignment during reassembly. (See Figure 16.) Slide water jacket(18) off cover (26) taking care not to damage gaskets (19 and 19A). Remove gaskets (19 and 19A).
12. On Model 1520/2520, remove capscrews (39 and 62) and washers (40 and 63) to take off supports (41 and 64). On Model 1550/2550 frame sizes 143 thru 184 JP only, unscrew capscrews (39) and remove washers (40) and support (41) from bracket (35).
13. Unscrew capscrews (32) to remove bracket (35) from frame (57) on Model 1520/2520 or motor on Models 1550/2550 and 1530/2530.

14. For Models 2550, 2530, 2520: The seal flexible cup and stationary seat should be pressed out of the bracket (35) and the cavity cleaned of all residue. Make sure that the 1/32" radius in the seal seat cavity is not damaged during disassembly since a sharp edge can easily cut the flexible cup during reassembly.
15. Remove key (42) from the shaft and remove slingers (47). (1520/2520)
16. Unscrew capscrews (48) and remove bearing cap (49). Remove gasket (50) and retainer ring (52). Slide out shaft (55) and bearings (53 and 54). Since bearings (53 and 54) are press fitted on the shaft, they will have to be pulled or pressed off the shaft. Remove grease seals (51) from frame (57), and bearing cap (49). (1520/2520)
17. Remove screws (33) and nameplate (34) only if replacement is necessary. (1520/2520)

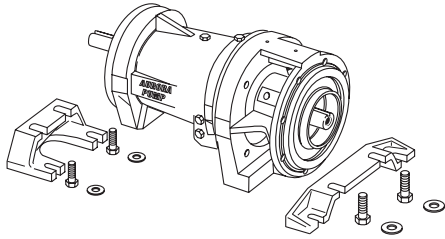

Fig. 21 2520 Support Feet Removed.

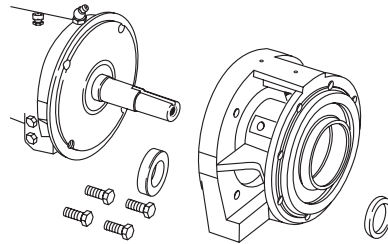

Fig. 22 2520 Bracket and Slinger Seal Flexible Cup and Stationary Seat Removed.

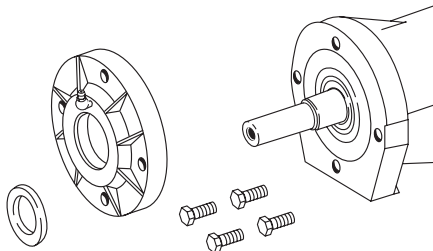

Fig. 23 2520/1520 Bearing Cap and Slinger Removed.

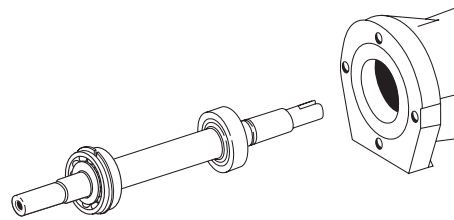

Fig. 24 2520/1520 Shaft Assembly Removed.

REASSEMBLY:

Reassembly will generally be in reverse order of disassembly. If disassembly was not complete, use only those steps related to your particular repair program.

1. Press grease seals (51) into frame (57) and bearing cap (49). (1520/2520)
2. Press bearings (53 and 54) onto shaft (55). Snap retainer ring (52) into place. (1520/2520)
3. Slide shaft (55) and bearings (53 and 54) into frame (57) and place gasket (50) in place. (1520/2520)
4. Fasten bearing cap (49) in position with capscrews (48). Position slingers (47) on the shaft. (1520/2520)
5. For Models 2550, 2530, 2520: The mechanical seal (27) (see Figure 25) cannot be installed as an assembly. It is necessary to have the seal seat properly in place in bracket (35) before the balance of parts can be added. Thoroughly inspect the seal cavity in seal bracket, checking for burrs or nicks which could damage flexible cup of mechanical seal. Apply a film of liquid dishwashing detergent (do not use oil or grease) to the flexible cup and seal seat. Insert seat in cup and install in seal bracket, taking care to seat it evenly and squarely.

NOTE:

If it is not possible to insert seat with fingers, place the cardboard protecting ring furnished with seal over lapped face of seat and press into place with a piece of tubing having end cut square. Tubing should be slightly larger than the diameter of the shaft. Remove cardboard after seat is firmly seated.

6. On Model 1520/2520, position bracket (35) on the frame (57) and secure with capscrews (32). Tighten screws evenly to assure proper alignment. On Models 1550/2550 and 1530/2530, position bracket (35) on the motor and secure with capscrews (32). Tighten screws evenly to assure proper alignment. On Model 1550, frame sizes 143 to 184 JP only, fasten support (41) to bracket (35) with washers (40) and capscrews (39).
7. If nameplate (34) was removed, install and attach with screws (33).
8. Replace wear ring(s) (7 and 16) in casing (6) and cover (26). Rings should not be hammered into place. Use a press, or clamp the parts in a bench vise, using wooden blocks to protect the rings. It may be necessary to pin or dowel the rings after assembly if the cover or casing has had rings replaced before, since each reassembly can stretch or tear metal and thereby loosen the fits. If the facilities are available, it is good practice to take a very light finish cut or to ream the inside diameter of the casing rings after pressing to restore roundness. When rings are pressed, they may get squeezed out of shape.
9. Coat the mating surfaces of impeller wear ring(s) (optional – 14 and 15) and impeller (11) with Loctite sealant grade 271. Replace wear rings, using the same care as for the case wear ring(s). If the rings are to be trued on a lathe, do not clamp the impeller so tightly that it is permanently distorted.
10. For Models 1550, 1530, 1520: If water jacket (optional – 18) was removed it may be replaced at this time. Replace gaskets (19 and 19A) on cover (26) and carefully slide on water jacket making sure desired alignment is achieved. (See Figure 16.) Snap retaining ring (17) behind water jacket (18) in groove provided on cover (26).
11. For Models 1550, 1530, 1520: Reassemble the various types of stuffing boxes as follows:

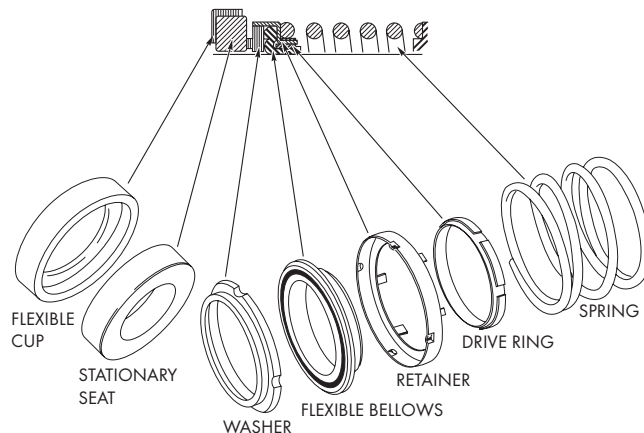

Fig. 25 Mechanical Seal (optional)

PACKING (STANDARD, WATER COOLED AND WITH LANTERN RING):

- A. If gland studs (24) are used, thread and tighten into either cover (26) or water jacket (18). Place one ring of packing (28) into the cover (26). On successive rings of packing, stagger the packing joints to prevent excessive leakage through the packing box. If a lantern ring (29) is used, place a second ring of packing (28) into the cover before installing lantern ring.

CAUTION:

- B. **There must be two (2) rings of packing in front of lantern ring (29) to assure proper alignment between the lantern ring and the sealing tube connection (69) in the cover (26). Install remaining packing rings (28). Each ring should be tapped firmly into place with a wood or metal bushing.**
- C. Replace pin (61) into the shaft sleeve (25) and slide the sleeve (25) through the packing, making sure the pin (61) end of the sleeve (25) is in the cover side opposite the gland halves (23).
- D. Replace gland halves (23) and gland clamps (22) on studs (24). Tighten nuts (21) down finger tight. For standard pumps, replace gland halves (23) and place gland clamps (22) over capscrews (65). Tighten capscrews (65) finger tight into either cover assembly (26) or water jacket (18). NOTE: The slots in gland halves (23) should be diagonal to pump horizontal center line.
- E. The cover assembly (26) as a unit may be replaced onto the motor shaft. Align key groove to facilitate impeller reassembly. The cover is held to motor bracket (35) by either capscrews (5) or (20). These should be installed and tightened at this time. When the pump is returned to service, additional care must be given to packing box to insure proper packing life. It is necessary to allow 60 to 120 drops leakage per minute through the packing for lubrication purposes. If the flow rate is other than this, the gland nuts or

capscrews should be either loosened or tightened one quarter turn at a time to acquire the correct leakage (both nuts or capscrews must be turned equally to prevent cocking of the gland). It will take approximately ten minutes at any one gland setting before the leakage rate will stabilize. When in doubt, choose the greater leakage rate since overly tight packing will ruin not only the packing, but the sleeve as well.

MECHANICAL SEAL (OPTIONAL):

The mechanical seal (27) (see Figure 25), should not be installed as an assembly. It is necessary to have the seal seat properly in place before the balance of parts can be added.

- A. Wipe the sealing faces of the seat and seal washer clean. Apply a film of liquid dishwashing detergent (do not use oil or grease) to the flexible bellows in the rotating assembly and shaft sleeve (25). Slide the entire rotating assembly onto the sleeve, making sure that the carbon washer faces away from the step in the sleeve.
 - B. Thoroughly inspect the gland (23), checking for burrs or nicks which could damage flexible cup of mechanical seal. Apply a film of liquid dishwashing detergent (do not use oil or grease) to the flexible cup. Insert seat in cup and install in gland (23). NOTE: If it is not possible to insert seat with fingers, place cardboard protecting ring furnished with seal overlapped face of seat and press into place with a piece of tubing having end cut square. The tubing should be slightly larger than the diameter of the shaft. Remove cardboard after seat is firmly in place. Carefully slip the seal gland assembly (23) over the shaft with the stationary seat facing away from the motor. Insert gasket (66) over shaft.
 - C. The shaft sleeve with the seal rotating assembly on it may now be replaced on the shaft. Carefully slide the seal gland (23) and gasket (66) onto the sleeve before seating the sleeve (25) against the shaft shoulder.
 - D. Carefully slip cover assembly (26) over the shaft into its original position and secure with either capscrews (20 or 5).
 - E. Position seal gland (23) and gasket (66) onto the cover (26) taking care to seat it evenly and squarely. Secure by tightening capscrews (65) evenly. Spring tension will probably prevent the sleeve from remaining in position axially until impeller is locked against it.
11. For Models 2550, 2530, 2520: Wipe the sealing faces of the seat and seal washer clean. Replace pin (61) in sleeve if it was removed during disassembly. Apply a film of liquid dishwashing detergent to the washer and bellows of the seal and slide the remaining seal parts onto the sleeve, making sure the washer is seated against the seal seat. Check the proper sequence of assembly as indicated in Figure 25. The shaft sleeve with the seal rotating assembly on it may now be replaced onto the motor shaft. Spring tension will probably prevent the sleeve from remaining in position axially until the impeller is locked against it.
 12. Carefully place gasket (10) on motor end of impeller. Assemble key (12) and impeller (11) to motor shaft. Secure impeller with gasket (9B), washer (9A), capscrew seal (9C) and impeller screw (9).
 13. On Model 1520/2520, fasten the supports (41 and 64) to bracket (35) and frame (57) with washers (40 and 63) and capscrews (39 and 62).
 14. Install the pipe plugs (4) in the pump casing (6). Position gasket (8) and casing (6) against the cover (26) and secure with capscrews (20 or 5).
 15. Reassemble sealing tube assembly (optional – 69, 70, 71, and 76) in water jacket (optional – 18) as shown in Figures 16 and 19. Replace all relief, cooling, flushings, or drain lines from the pump including compression connections (1 and 2) and tubing (3). On Model 1530/2530, position gasket (72) and set pump assembly in place. Tighten pump to base (73) with capscrews (39). Replace plugs (74 and 75). Replace all grease fittings, pipe plugs, tube vents and oiler assembly for oil lubricated units.
 16. Secure suction and discharge piping to the pump. Make sure to install gaskets on flanged connections.
 17. Connect electricity to the motor.
 18. Read carefully the section of the manual titled INSTALLATION, especially those paragraphs referring to pump and coupling alignment.

READ BEFORE INITIAL STARTING OR STARTING AFTER REASSEMBLY

STARTING PUMP AFTER REASSEMBLY:

Do not start pump until all air and vapor has been bled and until making sure that there is liquid in the pump to provide the necessary lubrication. Without the fluid around it, the seal may be ruined in a few seconds of operation. It is possible that the mechanical seal may drip during the first few minutes to one hour of operation.

WARNING: Hot Surface Hazard

If pumping hot water, ensure guards or proper insulation is installed to protect against skin contact to hot piping or pump components. Failure to follow these instructions could result in serious personal injury, death or property damage.

WARNING: Spraying Water Hazard

When servicing pump replace all gaskets and seals. Do not reuse old gaskets or seals. Failure to follow these instructions could result in serious personal injury, death or property damage.

WARNING: Electrical Shock Hazard

All electrical connections are to be made by a qualified electrician in accordance with all codes and ordinances. Failure to follow these instructions could result in serious personal injury, death or property damage.

WARNING: Electrical Overload Hazard

Ensure all motors have properly sized overload protection. Failure to follow these instructions could result in serious personal injury, death or property damage.

WARNING: Sudden Start-Up Hazard

Disconnect and lock out power source before servicing. Failure to follow these instructions could result in serious personal injury, death or property damage.

WARNING:

On the 1520 with a 15" impeller on a #21 power frame, reverse rotation will destroy the pump.

You must make sure that the motor rotates in the proper direction BEFORE coupling the motor to the pump. Start the drive motor to make sure the direction of rotation is the same as the direction indicated by the arrow on the pump casing.

The arrow on the casing always points clockwise when the pump is viewed from the motor end.

On 3 phase motors, you can reverse one of the power leads if the motor is not rotating clockwise.

WARNING:

Reverse rotation will quickly destroy the pump.

After you are sure the motor is rotating clockwise you can couple the motor to the pump. Again, after coupling but BEFORE starting it is important to check coupling and shaft alignment. Use a standard dial indicator to align the motor shaft and pump shaft to within 0.003"–0.005".

Model 1550 List of Parts

1. Elbow	9B. Gasket	19. Gasket	27. Seal
2. Connector	9C. Capscrew Seal	19A. Gasket	28. Packing
3. Tubing	10. Gasket	20. Capscrew	29. Lantern Ring
4. Plug, Pipe	11. Impeller	(not shown)	32. Capscrew
5. Capscrew	12. Impeller Key	21. Nut	33. Screw
6. Casing	14. Wear Ring	22. Clamp	34. Nameplate
7. Wear Ring	15. Wear Ring	23. Gland	35. Bracket
8. Gasket	16. Wear Ring	24. Stud	39. Capscrew
9. Impeller Screw	17. Retaining Ring	25. Sleeve	
9A. Washer	18. Jacket	26. Cover	

Model 1530 List of Parts

1. Elbow	11. Impeller	23. Gland	65. Capscrew
2. Connector	12. Impeller Key	24. Stud	66. Gasket
3. Tubing	14. Wear Ring	25. Sleeve	67. Plug, Pipe
4. Plug, Pipe	15. Wear Ring	26. Cover	68. Plug, Pipe
5. Capscrew	16. Wear Ring	27. Seal	69. Nipple
6. Casing	17. Retaining Ring	28. Packing	70. Gasket
7. Wear Ring	18. Jacket	29. Lantern Ring	71. Locknut
8. Gasket	19. Gasket	32. Capscrew	72. Gasket
9. Impeller Screw	19A. Gasket	33. Screw	73. Base
9A. Washer	20. Capscrew	34. Nameplate	74. Plug, Pipe
9B. Gasket	(not shown)	35. Bracket	75. Plug, Pipe
9C. Capscrew Seal	21. Nut	39. Capscrew	76. Coupling, Pipe
10. Gasket	22. Clamp	61. Pin	

Model 1520 List of Parts

1. Elbow	17. Retaining Ring	35. Bracket	55. Shaft
2. Connector	18. Jacket	39. Capscrew	56. Plug, Pipe
3. Tubing	19. Gasket	40. Washer	57. Frame
4. Plug, Pipe	19A. Gasket	41. Support	58. Grease Fitting
5. Capscrew	20. Capscrew	42. Key	59. Plug, Pipe
6. Casing	(not shown)	43. Grease Fitting	60. Oiler Assembly
7. Wear Ring	21. Nut	44. Tube, Vent	61. Pin
8. Gasket	22. Clamp	46. Plug, Pipe	62. Capscrew
9. Impeller Screw	23. Gland	47. Slinger	63. Washer
9A. Washer	24. Stud	47A. Slinger	64. Support
9B. Gasket	25. Sleeve	48. Capscrew	65. Capscrew
9C. Capscrew Seal	26. Cover	49. Bearing Cap	66. Gasket
10. Gasket	27. Seal	50. Gasket	67. Plug, Pipe
11. Impeller	28. Packing	51. Seal	68. Plug, Pipe
12. Impeller Key	29. Lantern Ring	51A. Seal	69. Nipple
14. Wear Ring	32. Capscrew	52. Retaining Ring	70. Gasket
15. Wear Ring	33. Screw	53. Bearing	71. Locknut
16. Wear Ring	34. Nameplate	54. Bearing	76. Coupling, Pipe

- NOTES:**
1. Bronze fitted construction will be furnished as standard unless specified otherwise.
 2. Refer to factory for special alloys.
 3. Fairbanks Nijhuis reserves the right to substitute materials without notice.
 4. Piece numbers 14 & 15 are not furnished as standard. When furnished, impeller must be modified.
 5. Piece numbers 39, 40, 41 used only with motor frames 143 through 184-JM on Model 1550 pumps.

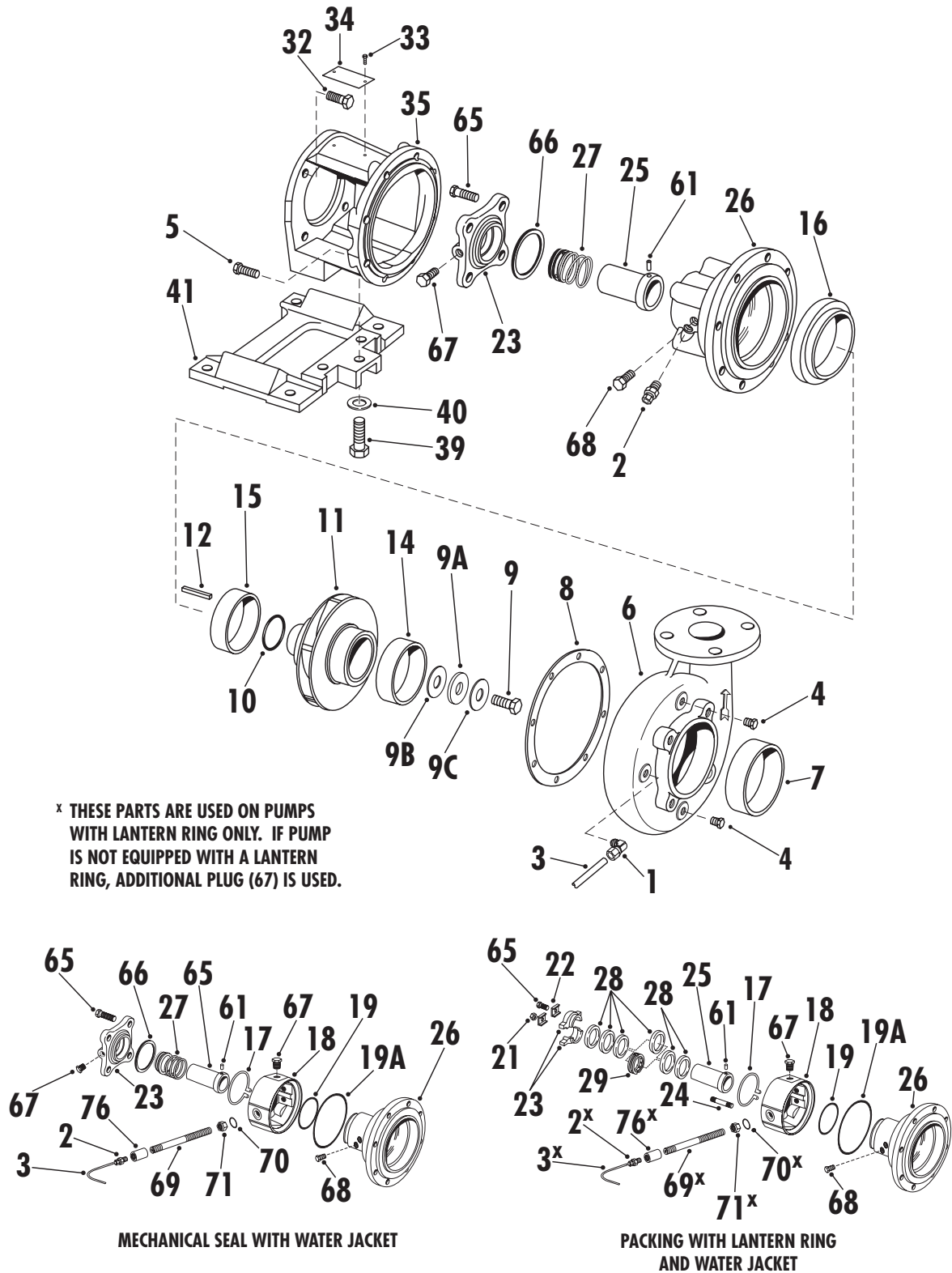

Fig. 26 Model 1550 Exploded View.

WHEN ORDERING SPARE PARTS ALWAYS INCLUDE THE PUMP TYPE, SIZE, SERIAL NUMBER, AND THE PIECE NUMBER FROM THE EXPLODED VIEW IN THIS MANUAL.

ORDER ALL PARTS FROM YOUR LOCAL AUTHORIZED DISTRIBUTOR.

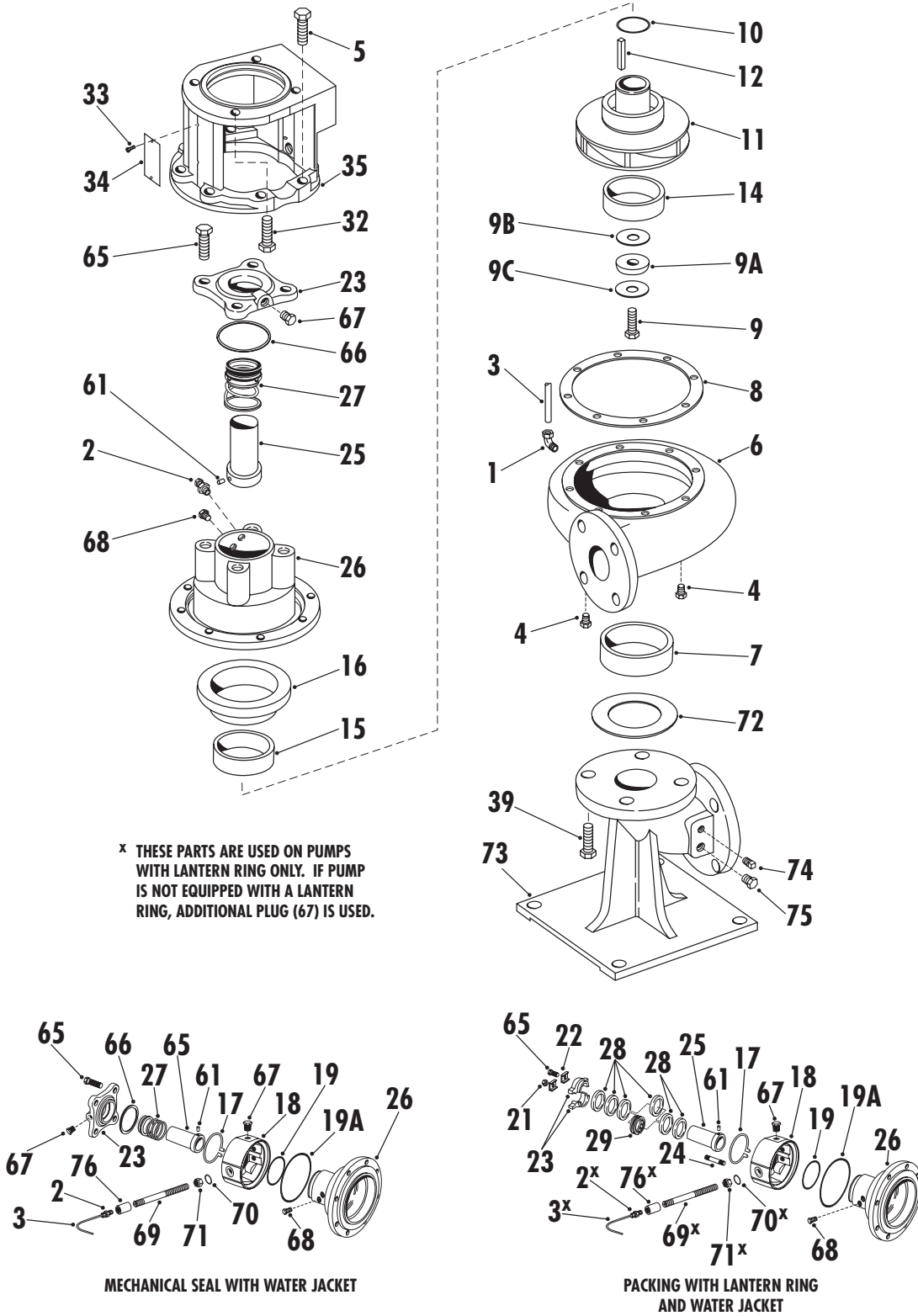

Fig. 27 Model 1530 Exploded View.

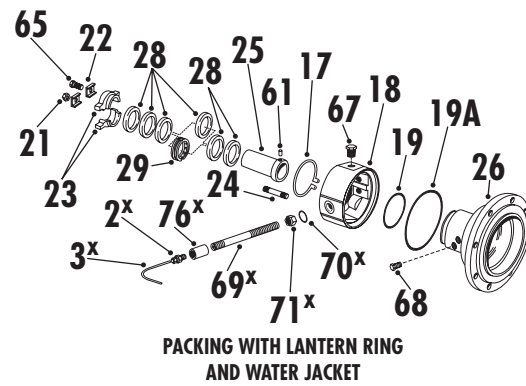
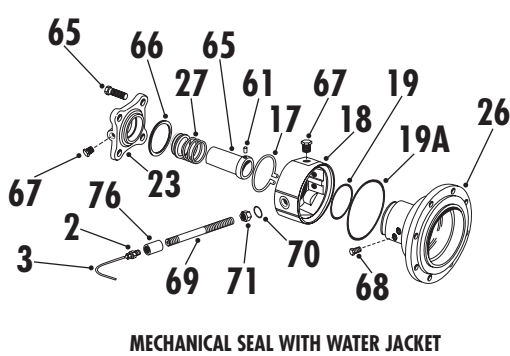
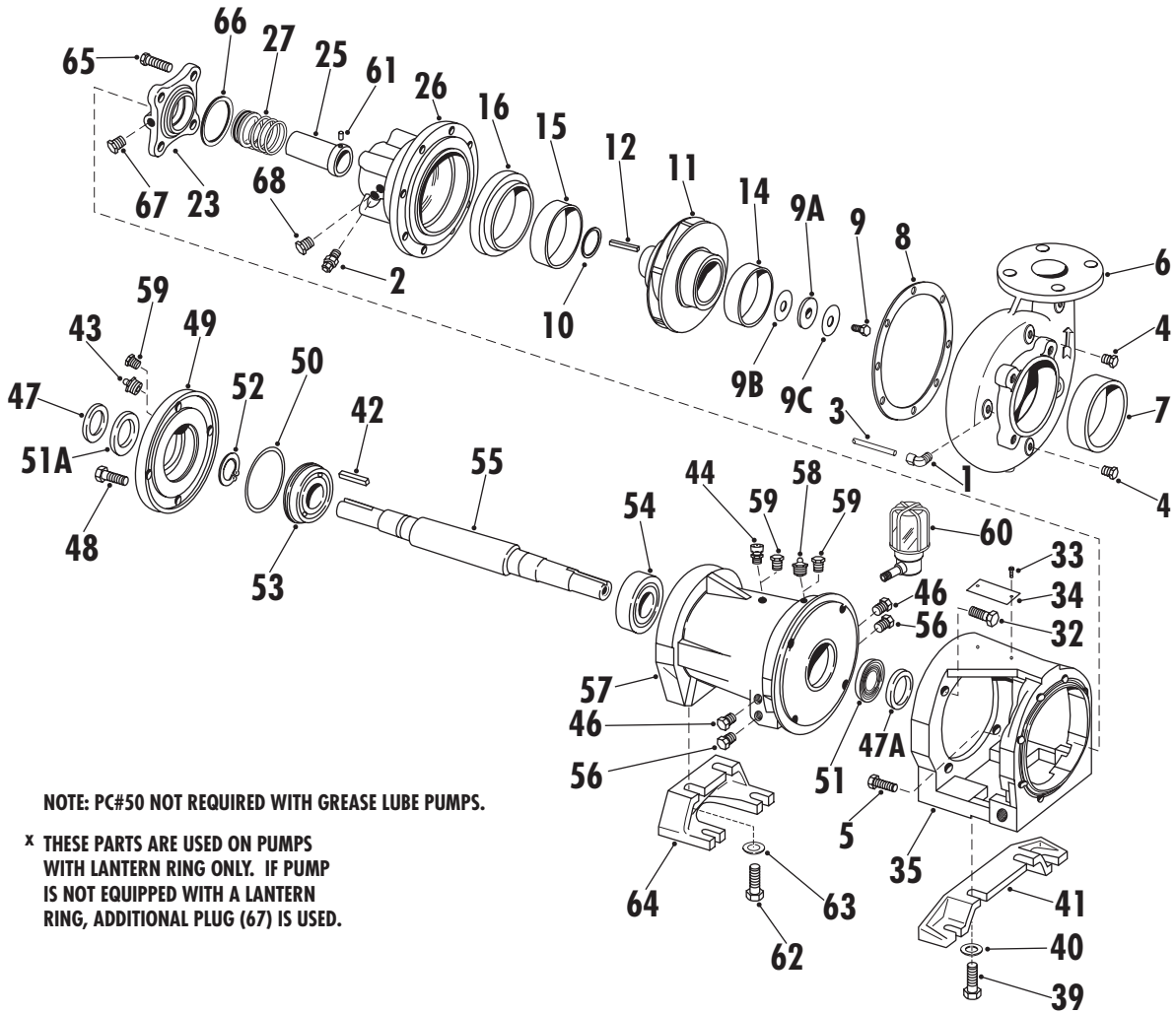

Fig. 28 Model 1520 Exploded View.

Model 2550 List of Parts

1. Elbow	8. Gasket	12. Impeller Key	33. Screw
2. Connector	9. Impeller Screw	14. Wear Ring	34. Nameplate
3. Tubing	9A. Washer	15. Wear Ring	35. Bracket
4. Plug, Pipe	9B. Gasket	16. Wear Ring	39. Capscrew
5. Capscrew	9C. Capscrew Seal	25. Sleeve	40. Washer
6. Casing	10. Gasket	27. Seal	41. Support
7. Wear Ring	11. Impeller	32. Capscrew	61. Pin

Model 2530 List of Parts

1. Elbow	9. Impeller Screw	15. Wear Ring	39. Capscrew
2. Connector	9A. Washer	16. Wear Ring	61. Pin
3. Tubing	9B. Gasket	25. Sleeve	72. Gasket
4. Plug, Pipe	9C. Capscrew Seal	27. Seal	73. Base
5. Capscrew	10. Gasket	32. Capscrew	74. Plug, Pipe
6. Casing	11. Impeller	33. Screw	75. Plug, Pipe
7. Wear Ring	12. Impeller Key	34. Nameplate	
8. Gasket	14. Wear Ring	35. Bracket	

Model 2520 List of Parts

1. Elbow	11. Impeller	41. Support	53. Bearing
2. Connector	12. Impeller Key	42. Key	54. Bearing
3. Tubing	14. Wear Ring	43. Grease Fitting	55. Shaft
4. Plug, Pipe	15. Wear Ring	44. Tube, Vent	56. Plug, Pipe
5. Capscrew	16. Wear Ring	46. Plug, Pipe	57. Frame
6. Casing	25. Sleeve	47. Slinger	58. Grease Fitting
7. Wear Ring	27. Seal	47A. Slinger	59. Plug, Pipe
8. Gasket	32. Capscrew	48. Capscrew	60. Oiler Assembly
9. Impeller Screw	33. Screw	49. Bearing Cap	61. Pin
9A. Washer	34. Nameplate	50. O-Ring	62. Capscrew
9B. Gasket	35. Bracket	51. Seal	63. Washer
9C. Capscrew Seal	39. Capscrew	51A. Seal	64. Support
10. Gasket	40. Washer	52. Retaining Ring	

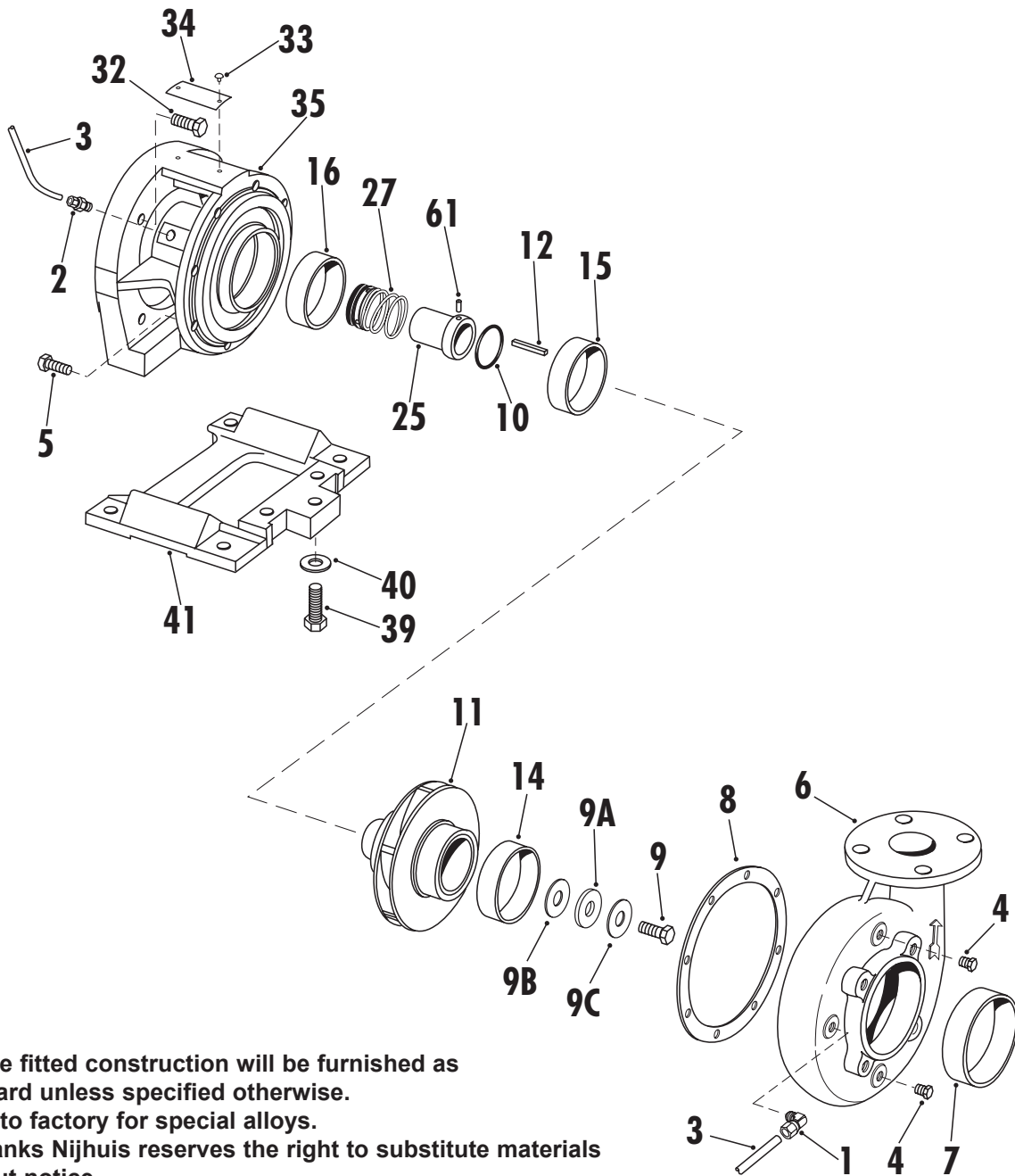

NOTES:

1. Bronze fitted construction will be furnished as standard unless specified otherwise.
2. Refer to factory for special alloys.
3. Fairbanks Nijhuis reserves the right to substitute materials without notice.
4. Piece numbers 14 and 15 are not furnished as standard. When furnished, impeller must be modified.
5. Piece numbers 39, 40, 41 used only with motor frames 143 through 184-jm on Model 2550 pumps.

Fig. 29 Model 2550 Exploded View

WHEN ORDERING SPARE PARTS ALWAYS INCLUDE THE PUMP TYPE, SIZE, SERIAL NUMBER, AND THE PIECE NUMBER FROM THE EXPLODED VIEW IN THIS MANUAL.

ORDER ALL PARTS FROM YOUR LOCAL AUTHORIZED DISTRIBUTOR.

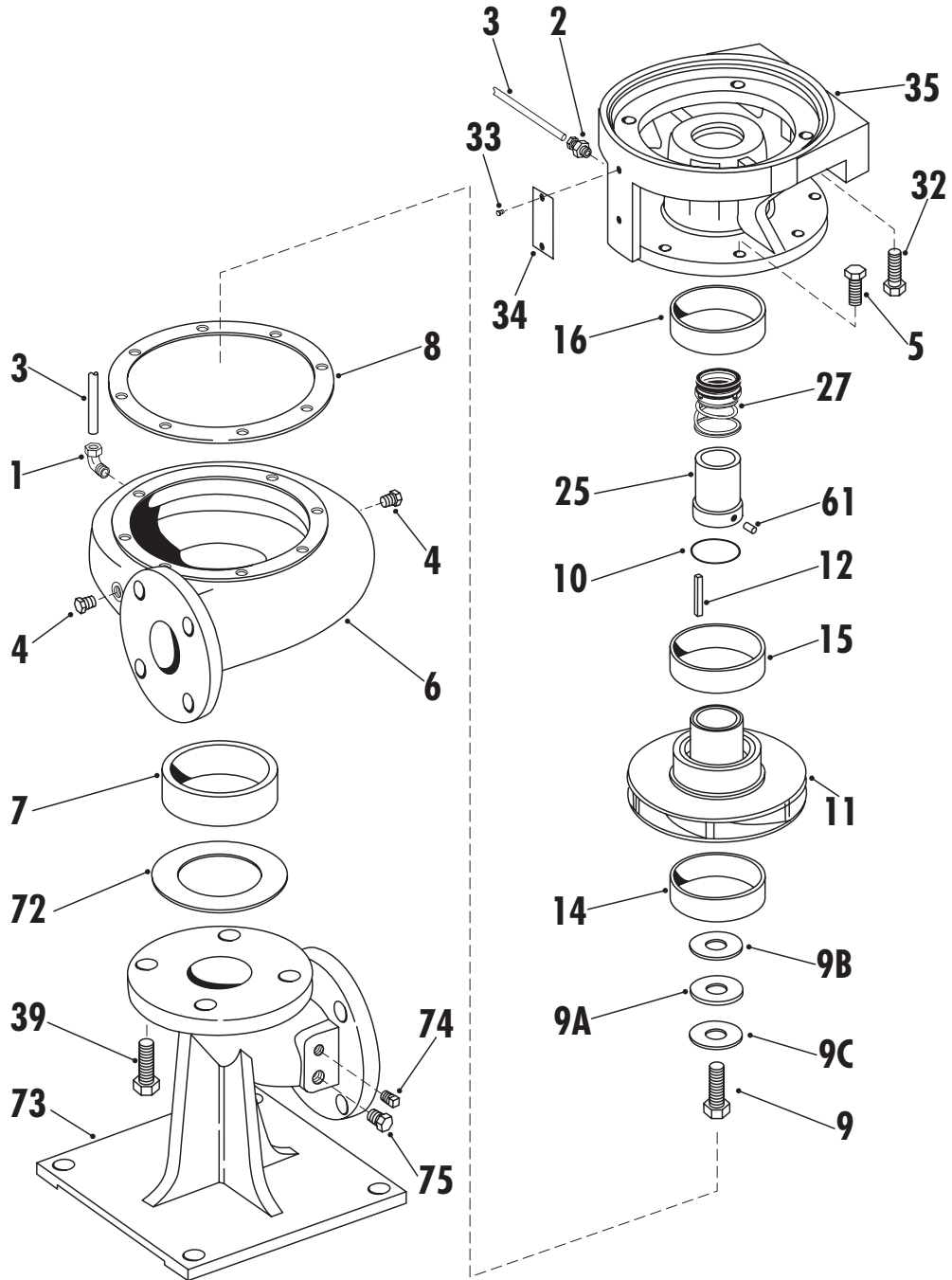

Fig. 30 Model 2530 Exploded View

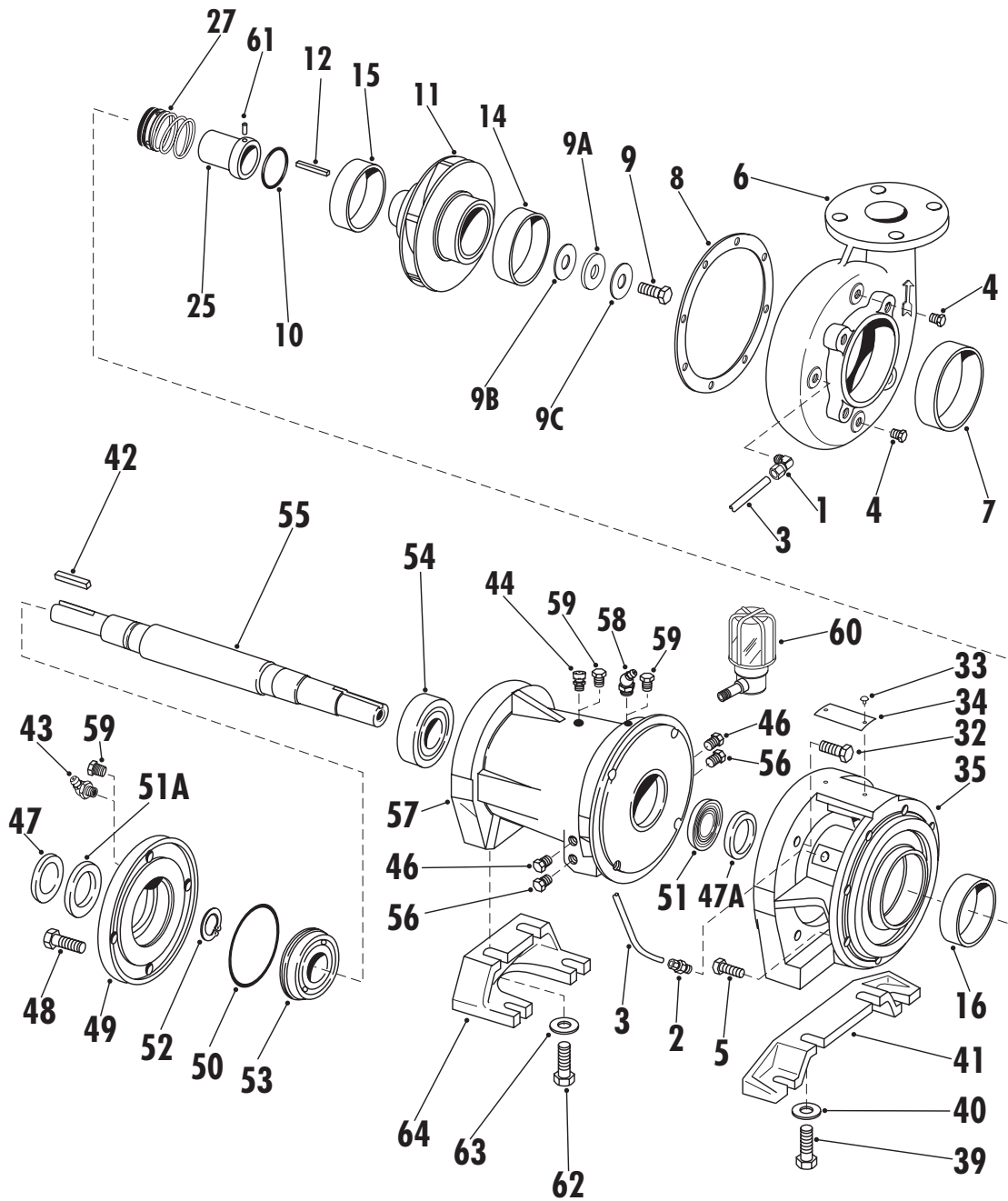

Fig. 31 Model 2520 Exploded View

THIS PAGE INTENTIONALLY LEFT BLANK