



FAIRBANKS NIJHUIS™

MODEL 1590F
VERTICAL INLINE FIRE PUMP
INSTRUCTION AND INSTALLATION MANUAL

NOTE! To the installer: Please make sure you provide this manual to the owner of the equipment or to the responsible party who maintains the system.

ATTENTION: SAFETY WARNINGS:

Model 1590F pumps are furnished with packing and lantern ring when suction pressure is 30 PSIG or less and packing only when suction pressure is greater than 30 PSIG.

CALIFORNIA PROPOSITION 65 WARNING: **Warning:**

This product and related accessories contain chemicals known to the State of California to cause cancer, birth defects or other reproductive harm.

LOCATION:

The pump should be installed in a clean, heated and well ventilated area that allows access for inspection, cleaning and proper maintenance. Sufficient space should be provided for installation and removal.

MOUNTING:

Model 1590F pumps have been designed with an assembled column base to support the pump and motor. The column base may be floor mounted or mounted to another base.

PIPING:

Suction and discharge piping must not be smaller than the inlet and outlet piping sizes of the pump. Piping connections must be tight, particularly the suction, as air leakage can cause reduced capacity or loss of prime. Isolation valves should be provided in suction and discharge lines.

CAUTION

Check the pump for pipe strain. Forcing the pipe to align with the pump flanges or inadequate support of suction and discharge piping can result in binding of the rotating element. Failure to conform to these precautions can result in malfunction or damage to the pump and motor

ELECTRICAL SAFETY: **Warning:** Electrical Shock Hazard

All electrical connections are to be made by a qualified electrician in accordance with all codes and ordinances. Failure to follow these instructions could result in serious personal injury, death or property damage.

 **Warning:** Electrical Overload Hazard

Insure all motors have properly sized overload protection. Failure to follow these instructions could result in serious personal injury, death or property damage.

 **Warning:** Sudden Start-Up Hazard

Disconnect and lock out power source before servicing. Failure to follow these instructions could result in serious personal injury, death or property damage.

HIGH PRESSURE SAFETY: **Warning:** High Pressure Hazard

The pump is rated at a maximum of 175 psi at 150°F. Do not exceed this pressure. Install properly sized pressure relief valves in system. Failure to follow these instructions could result in serious personal injury, death or property damage.

WIRING AND CONTROLS:

Power supply connection to controls and motors must conform with national and local codes. Line voltage and wire capacity must agree with the ratings of the motor nameplate.

IMPELLER ROTATION:

Prime pump before starting the motor or damage can occur to close clearance rotating parts. Bleed all air from the pump casing and suction pipe by opening the pipe plug located on the discharge nozzle. If accessible, rotate shaft slowly to evacuate air trapped in the impeller passages.

Jog the motor to check that the motor shaft rotates clockwise, as indicated by the arrow on the pump casing. If rotation is counterclockwise, correct by changing two wire leads.

OPERATION:

Before starting the pump:

1. Check that the current supply agrees with the voltage and frequency of the motor nameplate.
2. Check that the motor is wired for correct voltage.
3. Check that thermal overload relays are correct size and set for operation.
4. Check that suction line valve is open and discharge line valve closed.

After starting the pump:

Check that the pump is operating smoothly and is not rubbing, which could be caused by pipe strain.

The pump is provided with a circulation relief valve that prevents overheating when the pump is operating at reduced capacity. The suction valve should be full open and not be used for flow regulation. The discharge valve is used for flow regulation. Open the discharge valve slowly and check that pipe connections are sealed.

TROUBLESHOOTING:

If motor fails to start:

1. Wrong voltage, wiring hook up incorrect. Switches not set.
2. Rotating element may be bound due to clog in impeller pipe strain.
3. Tripped thermal overload relay or blown fuses.
4. Starter contacts may be shorted or corroded. Terminal connections may be broken at some point in the circuit.

Lost prime:

1. Suction pressure too low.
2. Leaks in suction piping connections.
3. High level of air entrainment.

Low or no water flow:

1. Speed may be low; check for low voltage.
2. The impeller may be clogged or damaged or suction and discharge lines partially clogged.
3. Valves may not be fully open.
4. Pump not primed.
5. Suction pressure may be low.
6. Required discharge pressure may be greater than originally anticipated.

Noise or vibration:

1. Partially clogged impeller resulting in imbalance.
2. Cavitation, net positive suction head available is too low.
3. Pump fully primed.
4. Foundation improperly secured or not strong enough.
5. Piping not anchored securely.
6. Rotating element binding due to damaged shaft worn bearings or pipe strain.

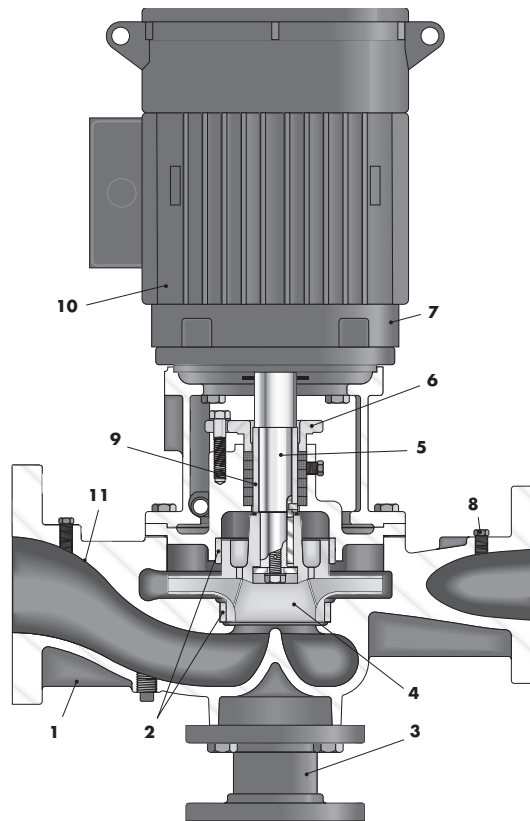

- 1 BACK PULL-OUT CASING with inline suction and discharge.
- 2 CASE WEARING RING prevents wear on casing and is easily and inexpensively replaced.
- 3 SUPPORT simplifies mounting. The pump can be fastened to the floor, a base or foundation.
- 4 DYNAMICALLY BALANCED IMPELLER is keyed to the shaft and secured by a capscrew and washer. Vacuum casting and quality controlled manufacturing process assures consistent high performance. Enclosed

design provides high efficiency and low wear for long service life.

- 5 CARBON STEEL SHAFT is designed for minimum deflection at maximum load.
- 6 TWO PIECE BRONZE PACKING GLAND provides easy packing maintenance.
- 7 FACTORY PERFORMANCE TEST guarantees performance at specified pump operating conditions.
- 8 FLUSH LINE with valve (when used) from discharge provides easy water seal adjustment to lantern ring.

- 9 BRONZE SHAFT SLEEVE extends full length of stuffing box to protect motor shaft. The shaft sleeve is slip fit over the shaft and then is keylocked. Shaft sleeve and impeller screw are sealed by O-ring gaskets to eliminate corrosion of the shaft by the pumped liquid.
- 10 STANDARD MOTOR approved for 1590F Series pump service by NEMA and the HYDRAULIC INSTITUTE provides low noise level pump operation.
- 11 VOLUTE TYPE SUCTION inlet prerotates suction liquid.

THIS PAGE INTENTIONALLY LEFT BLANK